

TRADE : DRAUGHTSMAN

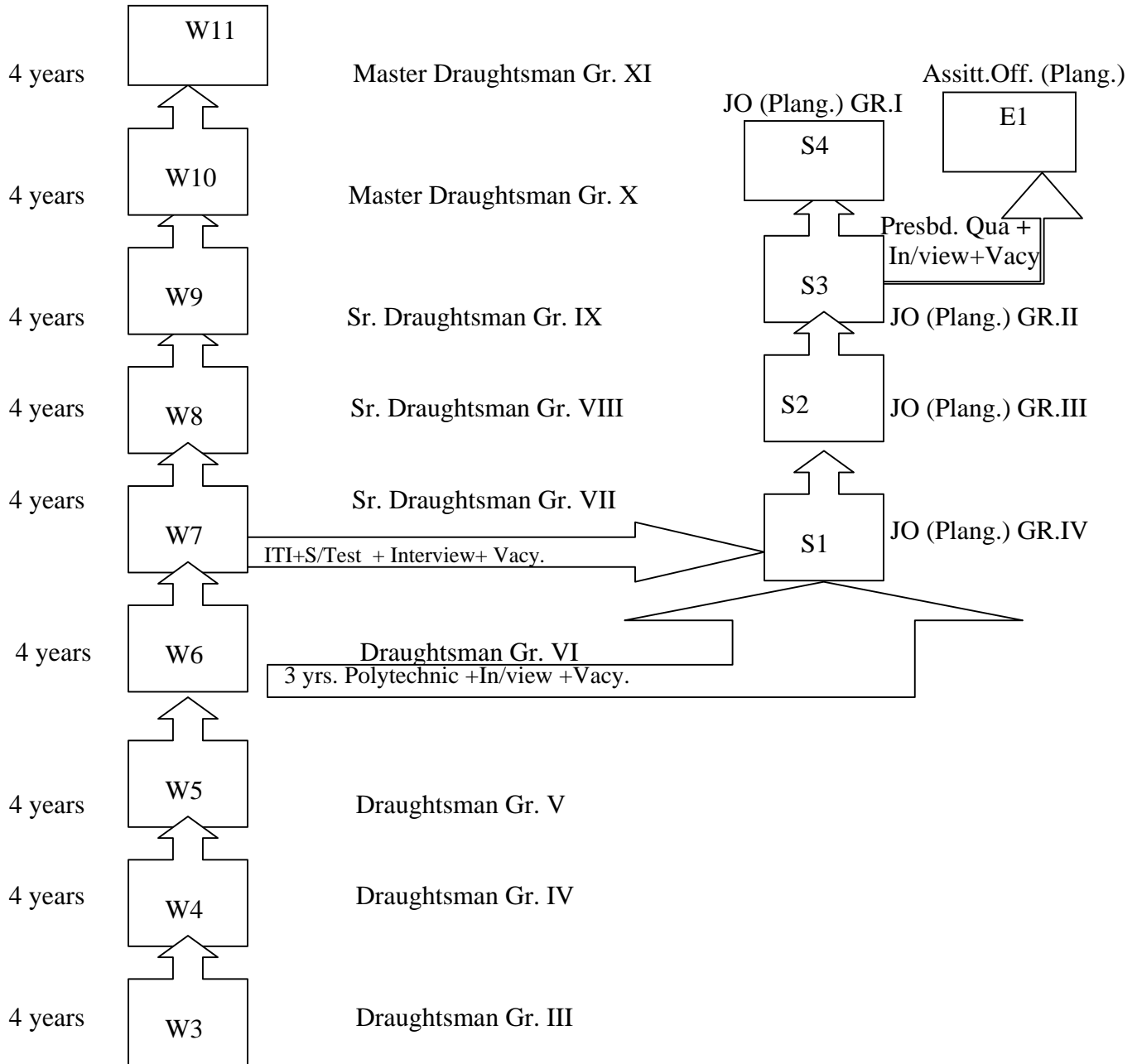

Note:

- Promotion beyond W9 will be on selection basis by conducting a departmental efficiency test. Employees who have completed 3 years at W9 level will be eligible to appear in the Departmental efficiency test.
- In Supervisory category Eligibility period will be 3 years and 4 years for employees possessing Polytechnic Diploma and ITI respectively.

**AREA : VEHICLE OPERATION
TRADE: OPERATOR/DRIVER**

**MINIMUM ELIGIBILITY
PERIOD**

DESIGNATION

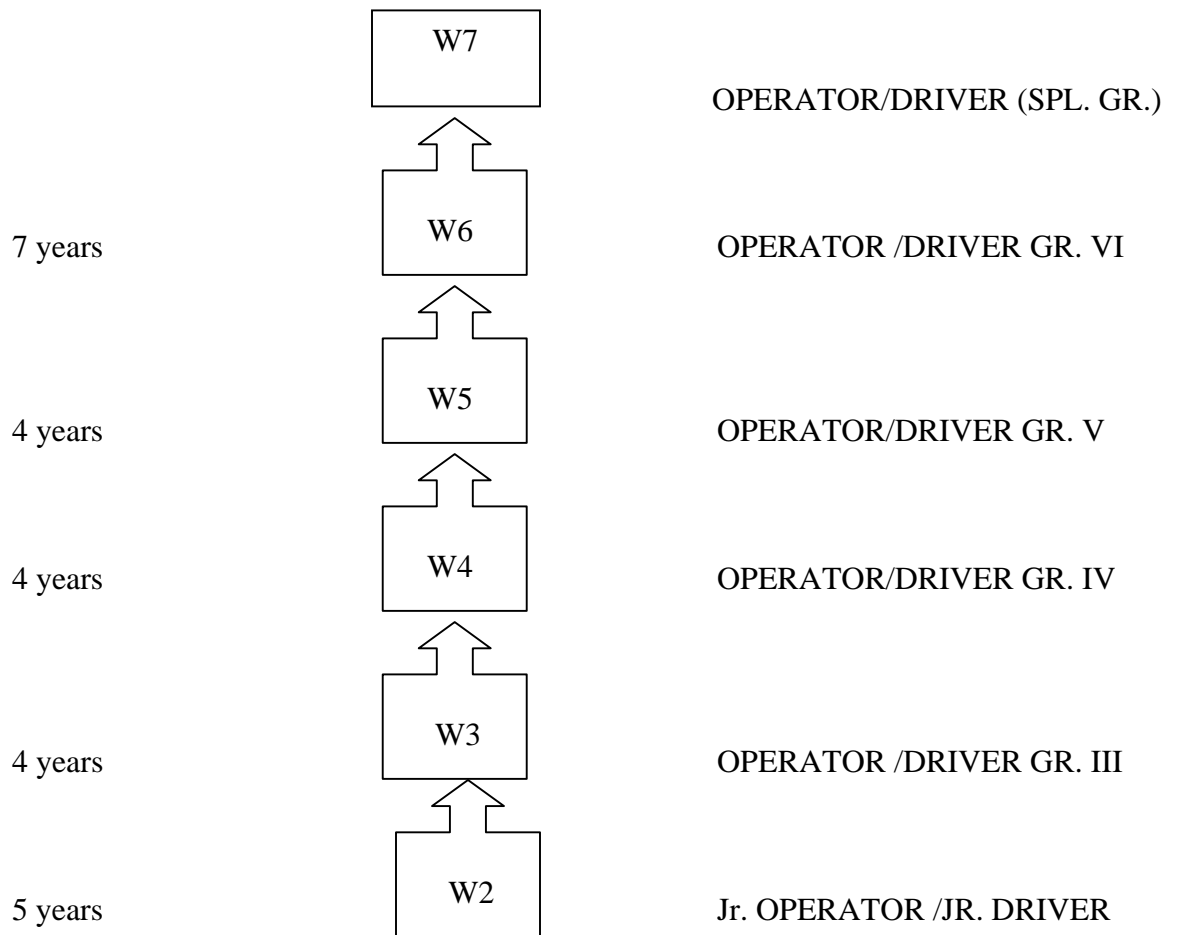

1. Trade includes LV/HMV, Road Roller/Tractor/Dozer/Shovel/Pay loader/Dumper/Loco DG/Forklift/Mixer/ Compressor etc.
2. At the lower level in the grade of W-4/W-5 one can change his line, if he has learnt Crane Operation as Crane Operator after proper selection as conducted from time to time on the basis of availability of vacancies.
3. From W6 to W7 (Special Grade) it will take 7 years as same is stagnation grade

TRADE : ARTISAN/OPERATOR

MINIMUM ELIGIBILITY PERIOD

DESIGNATION

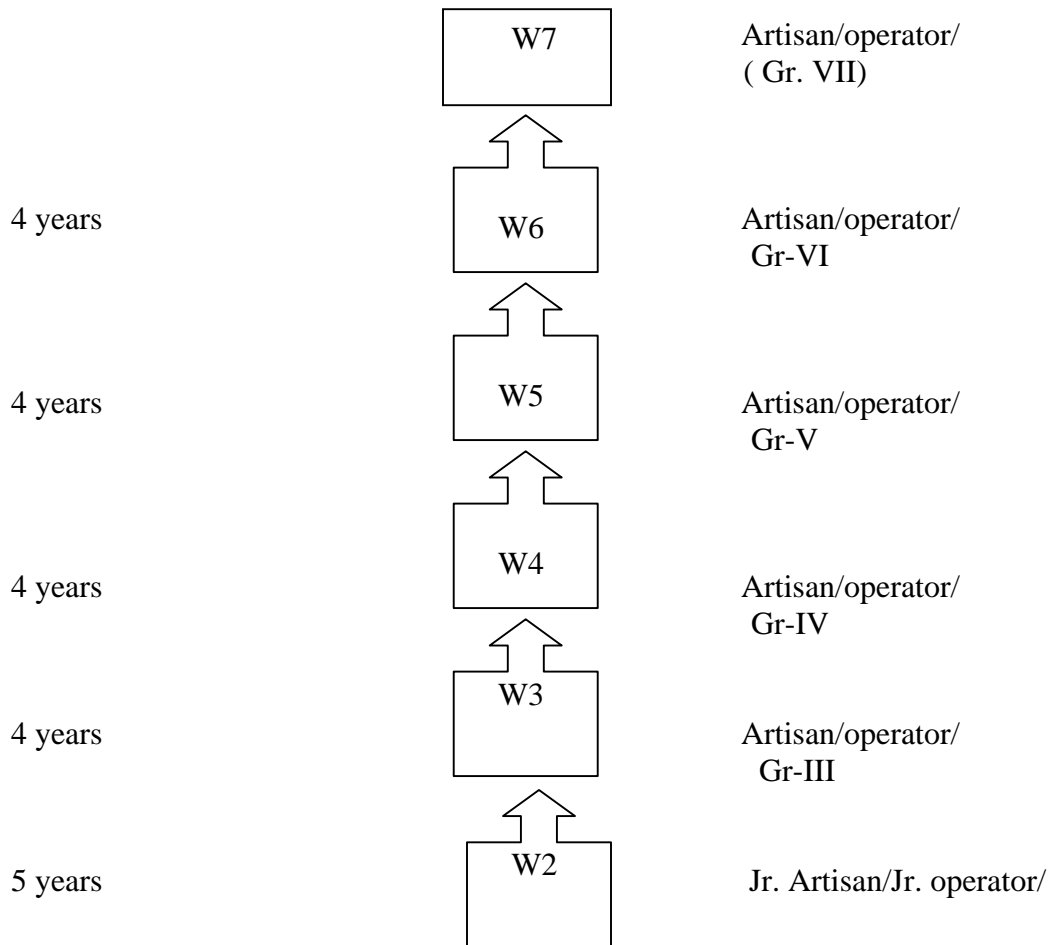

1. Artisan includes Plumbers, Carpenter, Black Smith, Mason, Painter and Operator includes Water Supply Pump Operator etc.
2. The movement to next higher level will be within one's respective trades.

**AREA : ADMINISTRATION
TRADE: COOK**

**MINIMUM ELIGIBILITY
PERIOD**

DESIGNATION

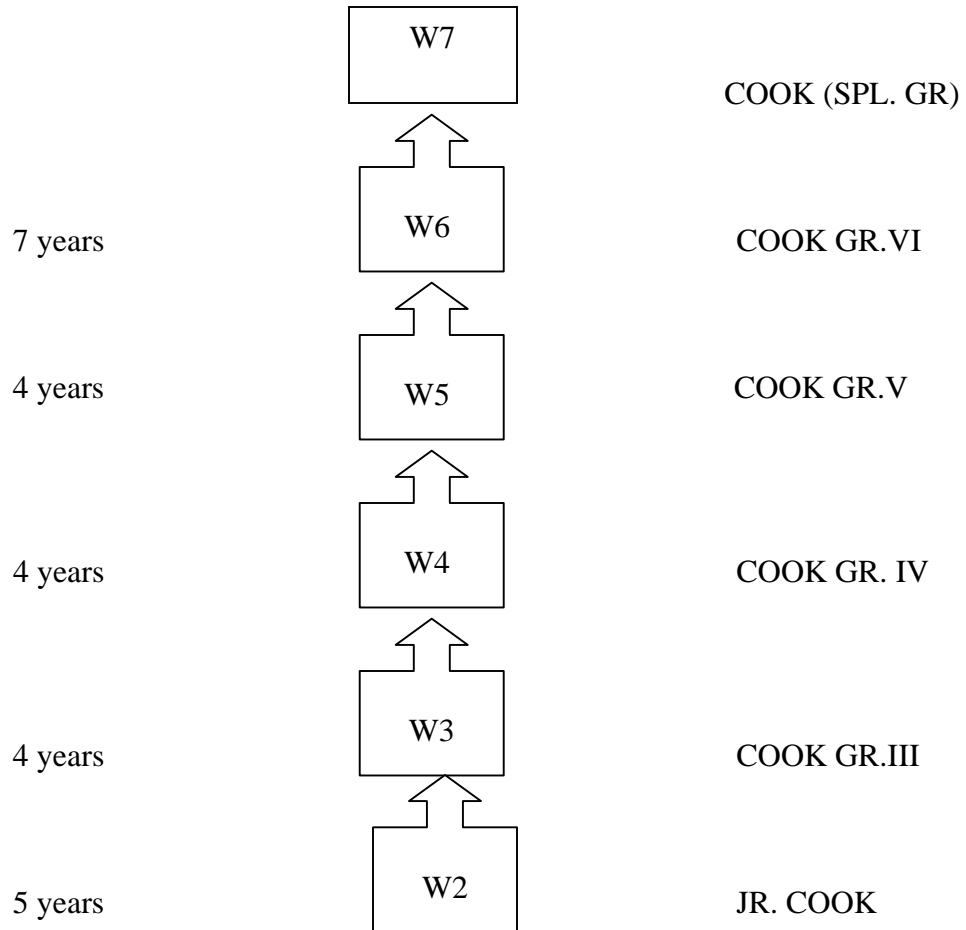

From W6 to W7 (Special Grade) it will take 7 years as the same is stagnation grade

**AREA: HOSPITAL
TRADE : TECHNICIAN (ECG)**

**MINIMUM ELIGIBILITY
PERIOD**

DESIGNATION

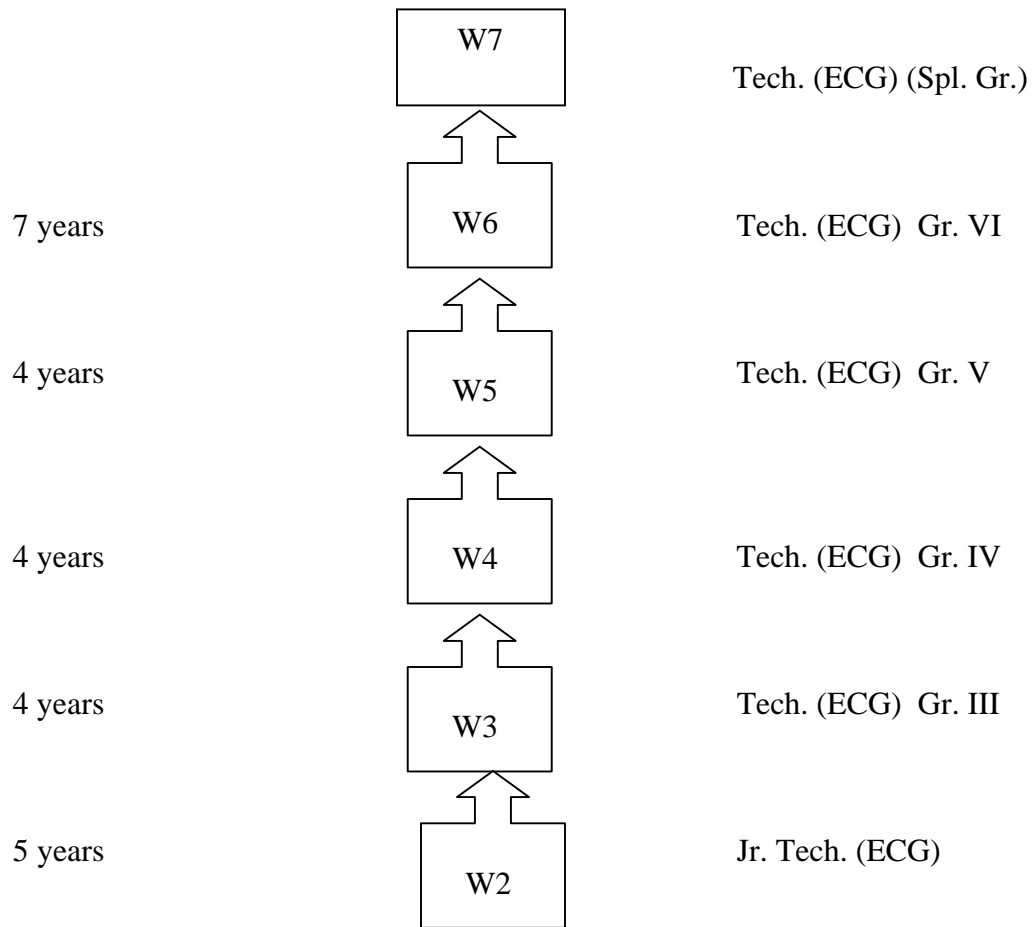

From W6 to W7 (Special Grade) it will take 7 years as the same is stagnation grade

AREA : HOSPITAL,

TRADE : MID WIFE

**MINIMUM ELEGIBILITY
PERIOD**

DESIGNATION

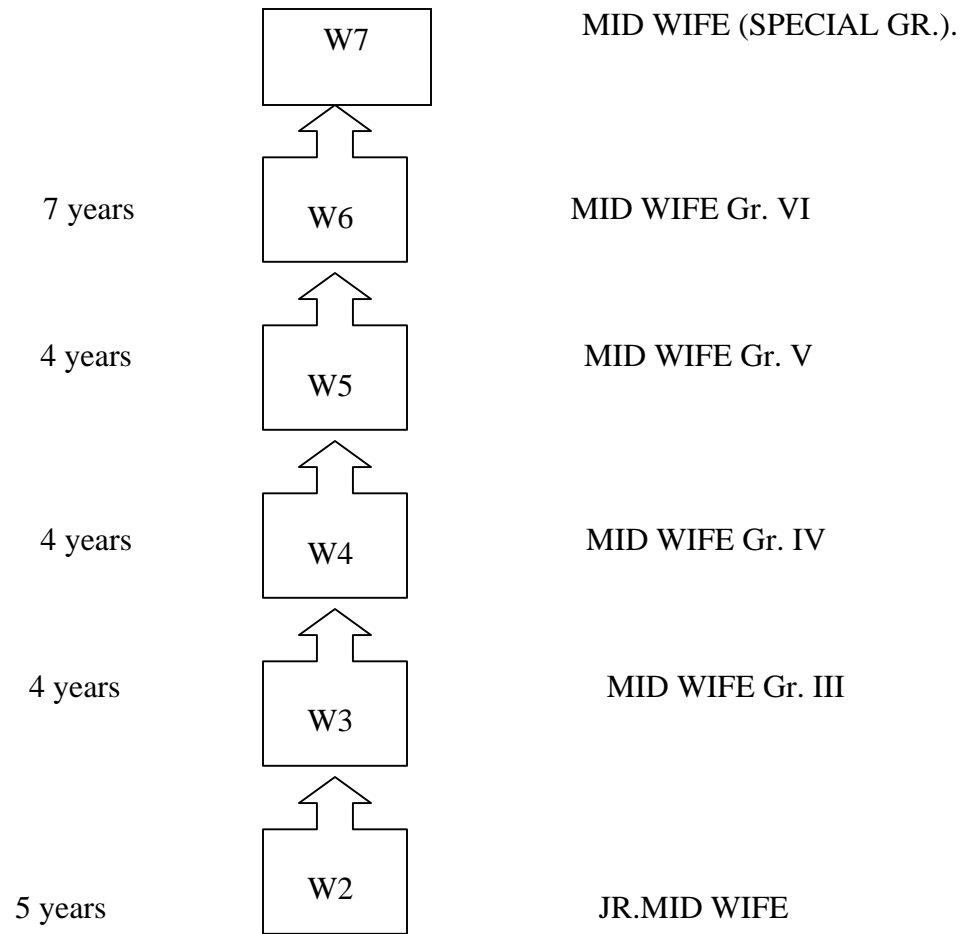

From W6 to W7 (Special Grade) it will take 7 years as the same is stagnation grade

**AREA: O&M
TRADE : RIGGER**

**MINIMUM ELIGIBILITY
PERIOD**

DESIGNATION

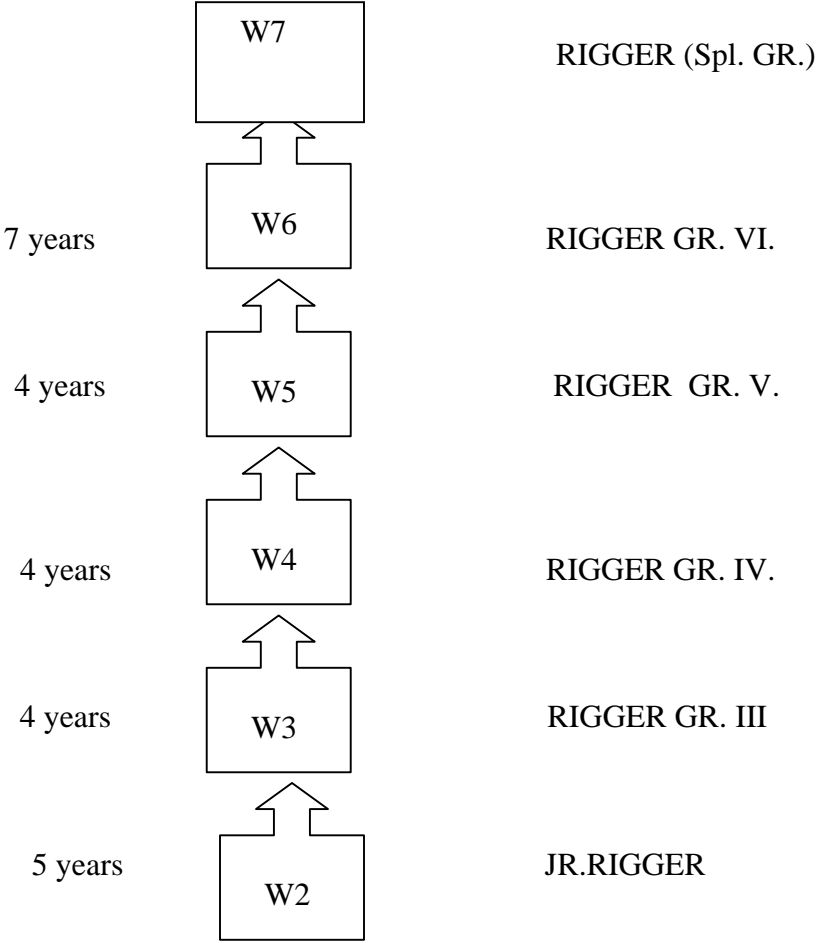

From W6 to W7 (Special Grade) it will take 7 years as the same is stagnation grade

**AREA : O&M/E&C
TRADE: TECHNICIAN**

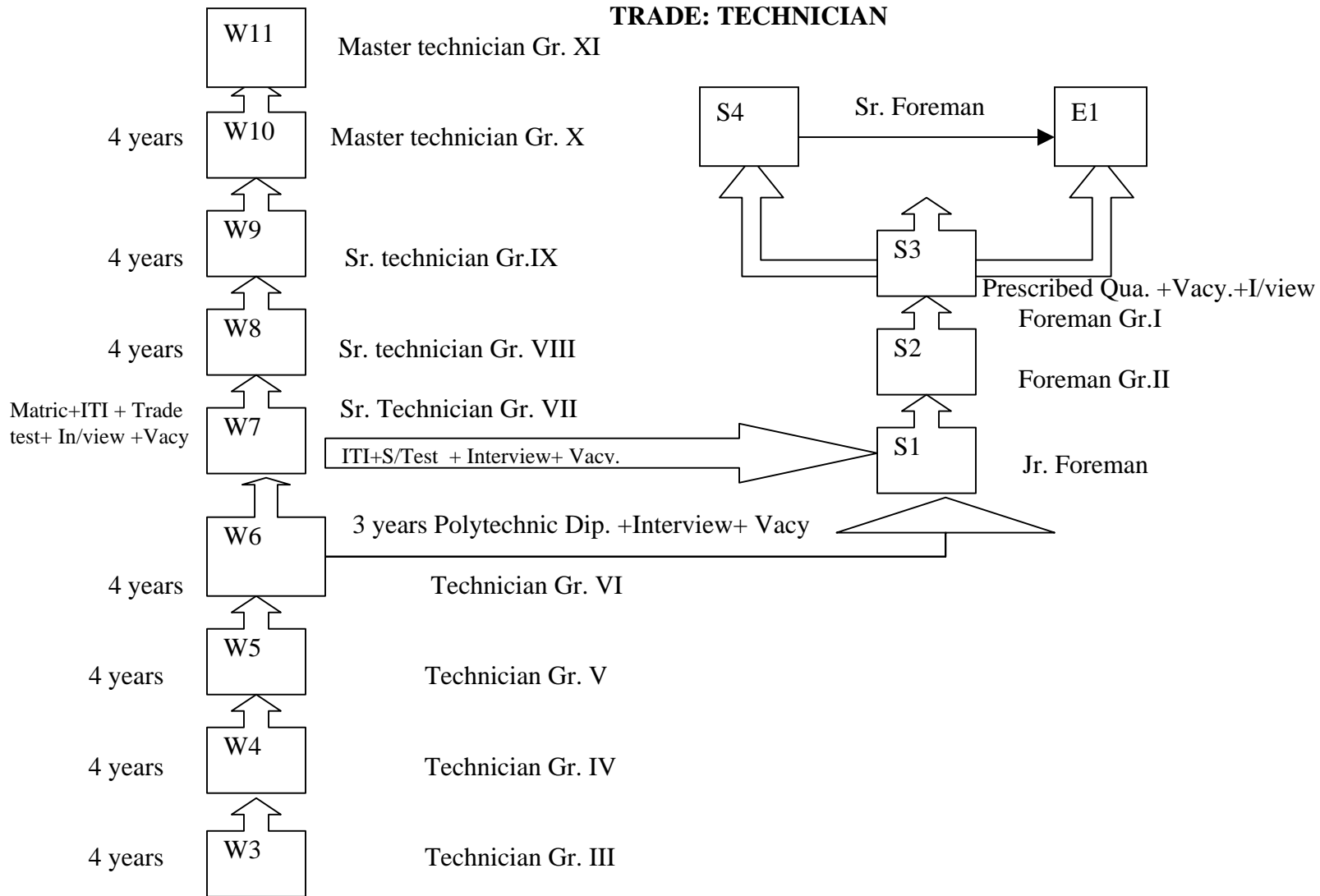

1. Technician includes Technician (Electro Mechanic/ Instrumentation/ AC&R), Fitter, Welder, Electrician, Turner, Valve fitter, Pump fitter, MGR fitter, MW fitter.
2. Posts in W-7 to W-11 will be limited and fewer in number, which will be determined by keeping in view the type of skill required and nature of responsibilities, equipment/process etc. Welder who posses valid HPW certificate only will be considered for these post.
3. Promotion beyond W9 will be on selection basis by conducting a departmental efficiency test. Employees who have completed 3 years at W9 level will be eligible to appear in the Departmental efficiency test.
4. In Supervisory category Eligibility period will be 3 years and 4 years for employees possessing 3 years Polytechnic Diploma and ITI respectively.

**AREA : HOSPITAL
TRADE: STAFF NURSE**

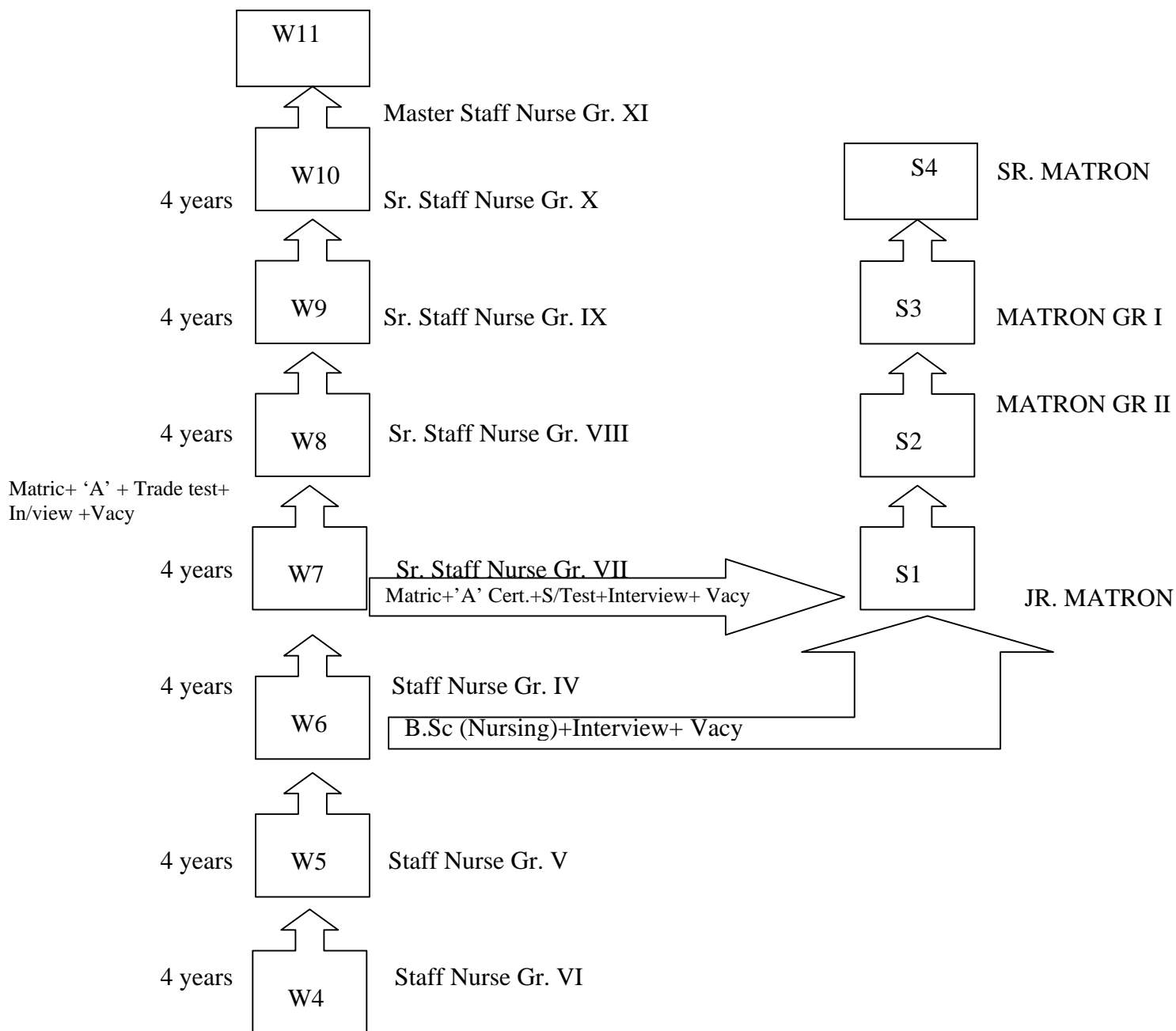

1. Promotion beyond W9 will be on selection basis by conducting a departmental efficiency test. Employees who have completed 3 years at W9 level will be eligible to appear in the Departmental efficiency test.
2. In Supervisory category Eligibility period will be 3 years and 4years for Employees possessing B. Sc. (Nursing) and A certificate respectively.

AREA: SECRETARIAL

TRADE: STENO

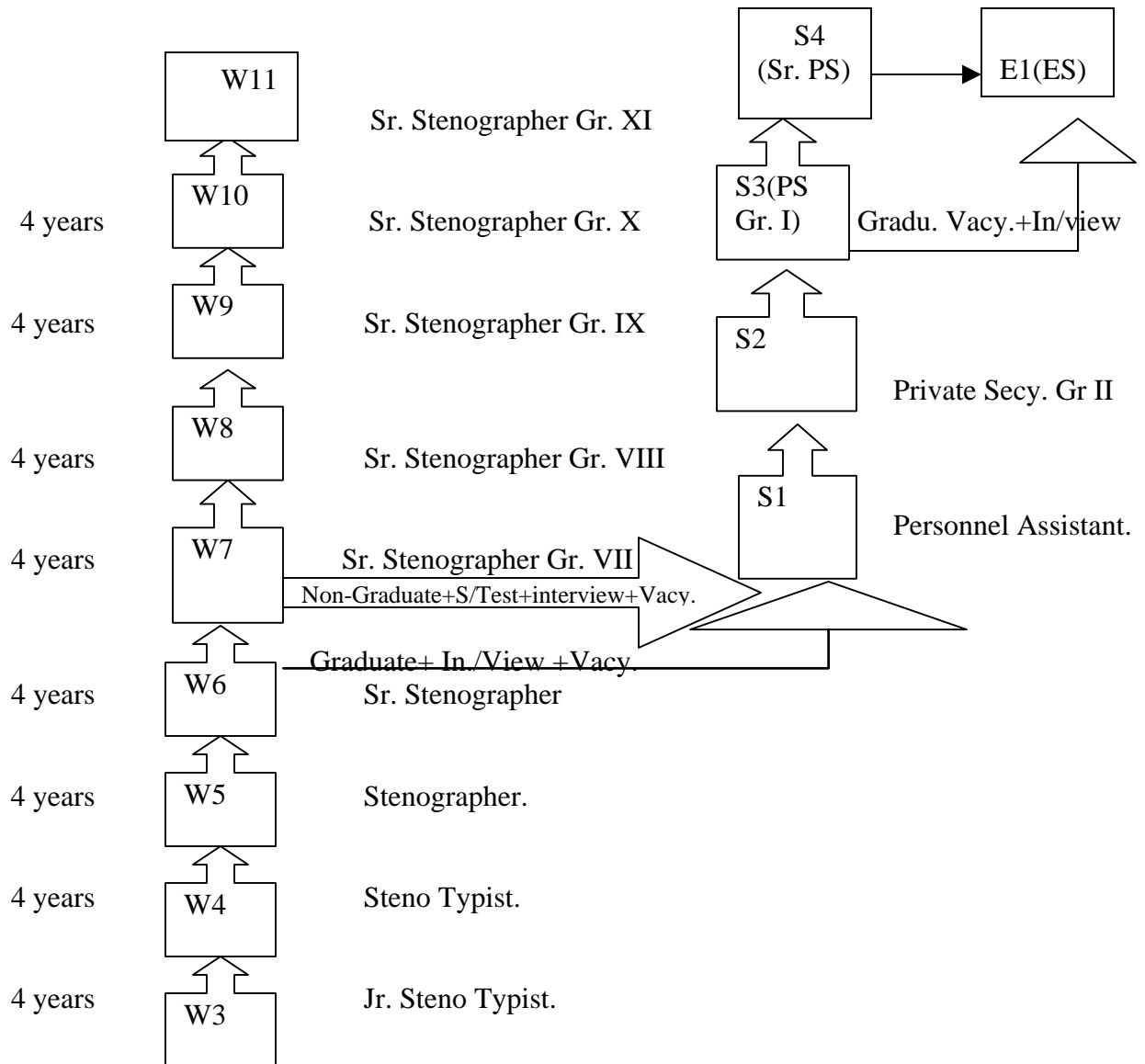

1. Promotion beyond W9 will be on selection basis by conducting a departmental efficiency test. Employees who have completed 3 years at W9 level will be eligible to appear in the Departmental efficiency test.
2. In Supervisory category Eligibility period will be 3 years for employees possessing Graduation.

**AREA – ALL
TRADE :ASSISTANT**

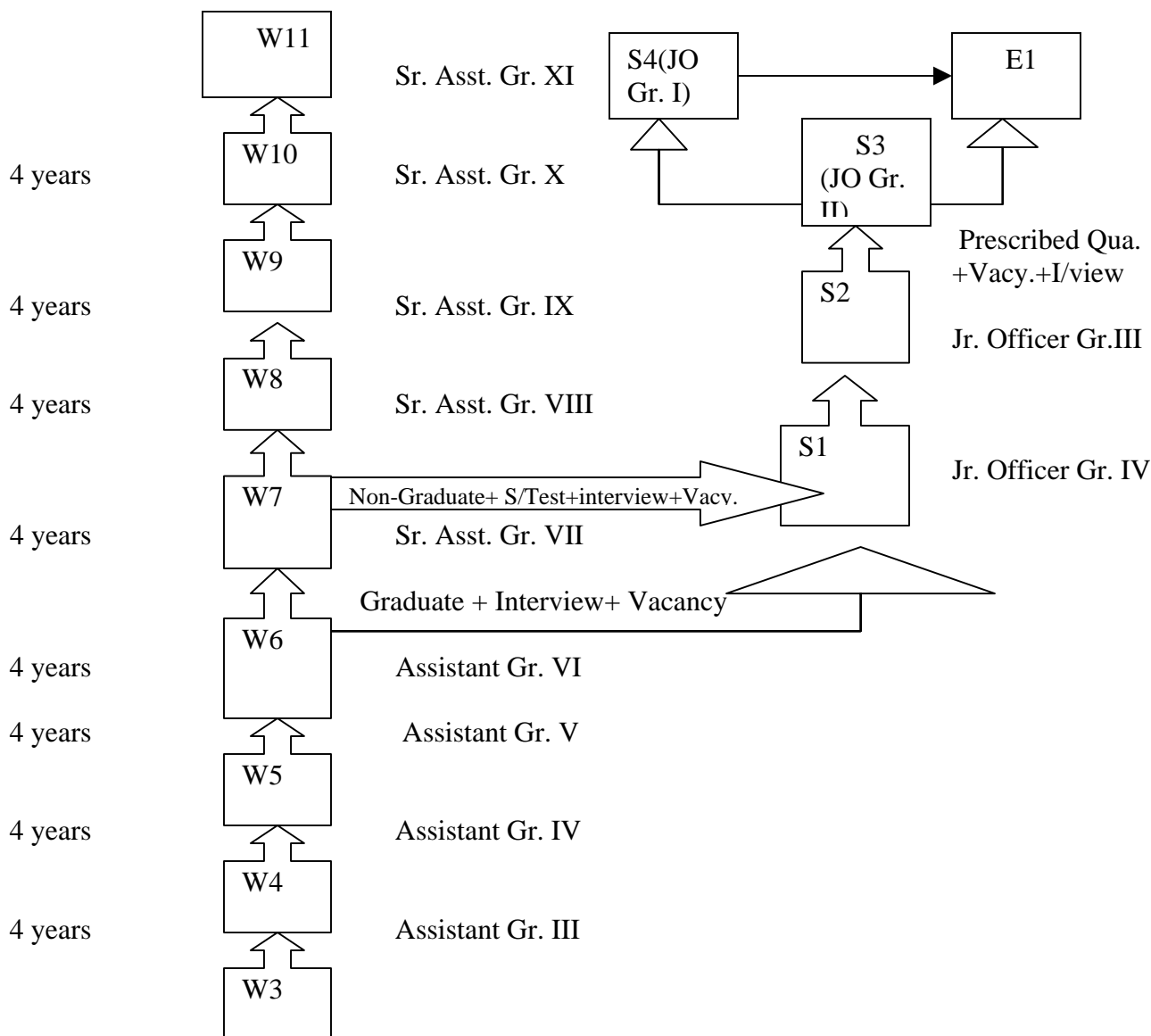

1. Assistants working in P&A, F&A & Material/Contracts may be considered for promotion beyond W7 subject to availability of vacancy.
2. In Supervisory category Eligibility period will be 3 years for employees possessing qualification as per job specification for Supervisors and 4 years for graduates.

AREA: HOSPITAL
TRADE: TECHNICIAN (RADIO-GRAPHY/LAB)

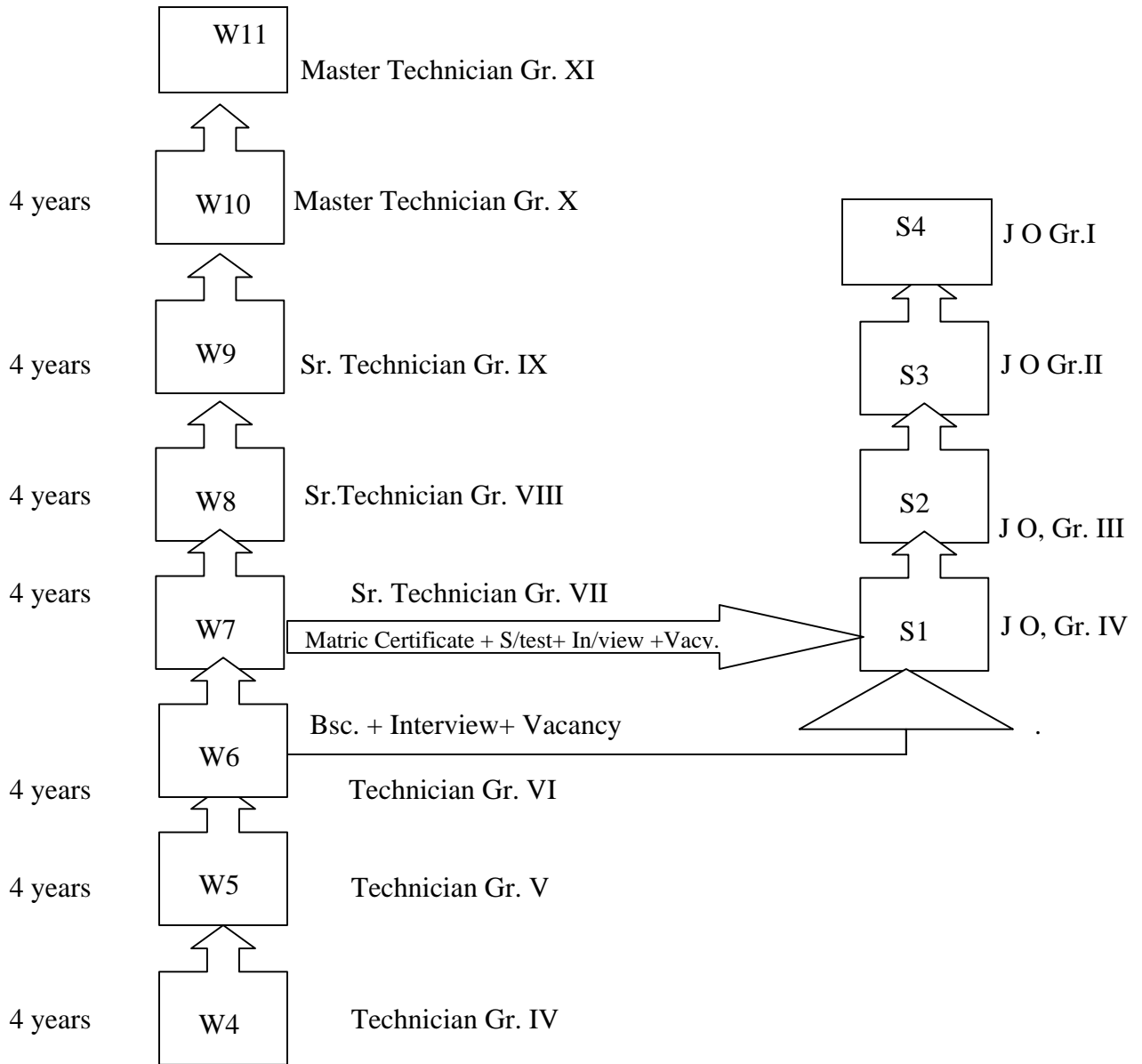

1. Promotion beyond W9 will be on selection basis by conducting a departmental efficiency test. Employees who have completed 3 years at W9 level will be eligible to appear in the Departmental efficiency test.
2. The employee must possess a certificate in Medical Lab. Technology and Radiography from recognized institution and hospital have sophisticated Radiography Machines/Laboratory for promotion to W7 & above.
3. In Supervisory category Eligibility period will be 3 years & 4 years for Employees possessing B.Sc. and Metric certificate respectively.

AREA:
TRADE:

ADMINISTRATION
WIRELESS OPERATOR

**MINIMUM ELIGIBILITY
PERIOD**

DESIGNATION

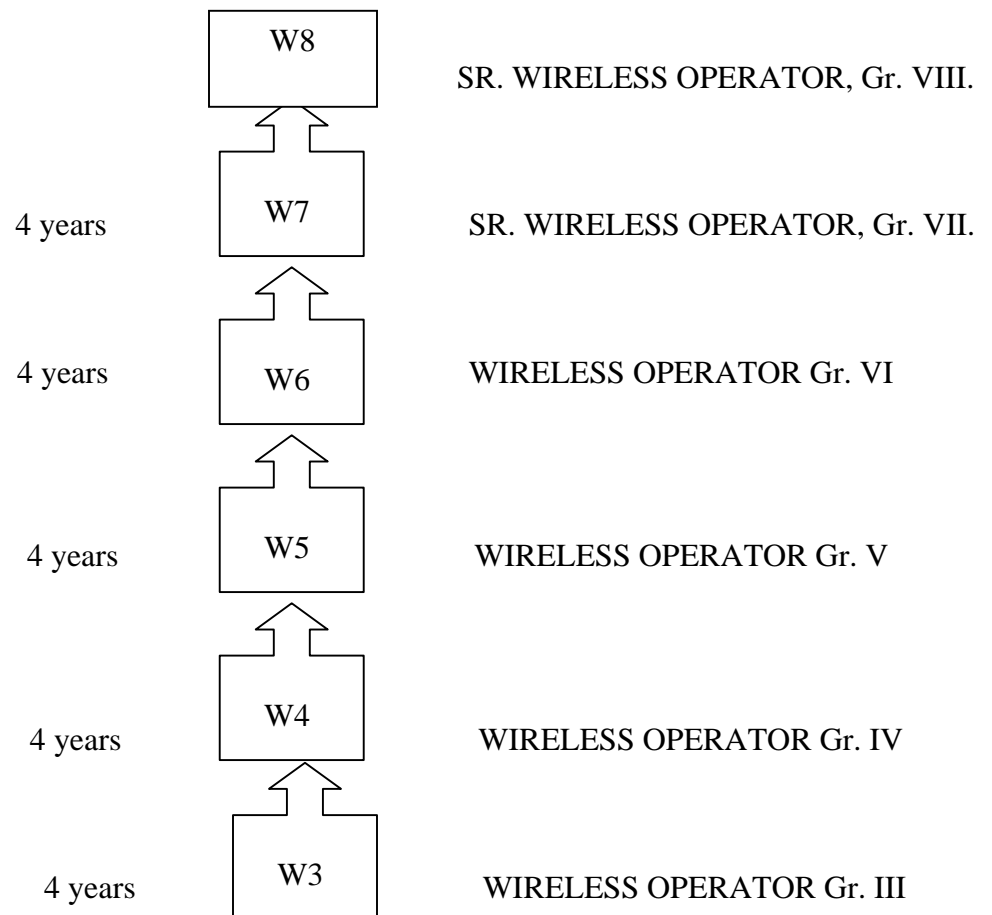

**AREA : HOSPITAL,
TRADE: PHARMACIST**

**MINIMUM ELEGIBILITY
PERIOD**

DESIGNATION

